

PLOS1178CAM

PORTAVALIGIE LATERALE SPECIFICO - SPECIFIC TUBULAR SIDE-CASE HOLDER - PORTE-VALISES LATÉRAUX SPÉCIFIQUE
SPEZIFISCHES STAHLROHR-SEITENTRAEGER - PORTA MALETAS LATERALES ESPECÍFICO - SUPORTE DE MALAS ESPECÍFICO

HONDA CRF1100L AFRICA TWIN (2020/2024)/

HONDA CRF1100L AFRICA TWIN ADVENTURE SPORTS (2020/2024)

N°	Descrizione/Description	Caratteristiche/Features	Codice/Code	Quantità/quantity
1	Telaio laterale - Side frame - Châssis latéral Soporte lateral - Seitenrahmen - Suporte lateral	-	PLOS1178DXV PLOS1178SXV	2 (Right: Left)
2	Supporto inferiore - Lower support - Support inférieur Soporte inferior - Untere Halterung - Suporte inferior	LEFT SIDE	GL5629V	1 (Left)
3	Supporto inferiore - Lower support - Support inférieur Soporte inferior - Untere Halterung - Suporte inferior	RIGHT SIDE	GL5630V	1 (Right)
4	Supporto anteriore - Front support - Support avant Vordere Unterstützung - Soporte frontal - Suporte frontal	-	GL5631DXV GL5631SXV	2 (Right: Left)
5	Supporto posteriore - Rear support - Hintere Unterstützung Support arrière - Soporte trasero - Suporte traseiro	-	GL5632DXV GL5632SXV	2 (Right: Left)
6	Ponte - Bridge - Pont Brücke - Puente - Ponte	-	GL5634V	1
7	Paracalore - Heat Guard Hitzeschutz - Pare Chaleur Protector De Calor - Protetor De Calor	-	GL5130V	1
8	Vite - Screw - Vis - Schraube Tornillo - Parafuso	TBEI M8x40	840TBEI	4
9	Vite - Screw - Vis - Schraube Tornillo - Parafuso	TCE M8x35	835TCE	4
10	Vite - Screw - Vis - Schraube Tornillo - Parafuso	TBEI M8x25	825TBEI	8
11	Vite - Screw - Vis - Schraube Tornillo - Parafuso	TSP M6x25	625TSP	2
12	Vite - Screw - Vis - Schraube Tornillo - Parafuso	TBEIFN M6x10	610TBEIFN	1
13	Vite - Screw - Vis - Schraube Tornillo - Parafuso	TSP 6x40	640TSP	1
14	Rondella spaccata - Split washer - Scheibe - Rondelle fendue Arandela seccionada - Arruela Dentada	Foro Ø8mm	Z1060	8
15	Rondella - Washer - Rondelle - Scheibe Arandela - Arruela	Foro Ø8mm	8RON	8
16	Rondella - Washer - Rondelle - Scheibe Arandela - Arruela	Foro Ø8mm / Esterno Ø20mm Sp.2mm	820RON	10
17	Rondella - Washer - Rondelle - Scheibe Arandela - Arruela	Foro Ø6mm / Esterno Ø18mm	618RON	2
18	Dado - Bolt - Ecrou Mutter - Tuerca - Porca	Dado Autobloccante Flangiato M8 (H.9mm)	8DADIFN	8
19	Dado - Bolt - Ecrou Mutter - Tuerca - Porca	Dado Autobloccante Flangiato Basso M6 (H.7mm)	6DADIABFN	2
20	Dado - Bolt - Ecrou Mutter - Tuerca - Porca	Dado Autobloccante Flangiato Ribassato Metalblock M6 (H.6mm)	6DADIAFL	1
21	Dado - Bolt - Ecrou Mutter - Tuerca - Porca	Dado Autobloccante M6 (H.6mm)	6DADIB	1
22	Distanziale - Spacer - Entretoise - Distanzstueck Distanciador - Espaçador	Ø16x4 Foro 8,5mm	C16L4F8,5T	1

PLOS1178CAM

PORTAVALIGIE LATERALE SPECIFICO - SPECIFIC TUBULAR SIDE-CASE HOLDER - PORTE-VALISES LATÉRAUX SPÉCIFIQUE
SPEZIFISCHES STAHLROHR-SEITENTRAEGER - PORTA MALETAS LATERALES ESPECÍFICO - SUPORTE DE MALAS ESPECÍFICO

HONDA CRF1100L AFRICA TWIN (2020/2024)/

HONDA CRF1100L AFRICA TWIN ADVENTURE SPORTS (2020/2024)

N°	Descrizione/Description	Caratteristiche/Features	Codice/Code	Quantità/quantity
23	Distanziale - Spacer - Entretoise - Distanzstueck Distanciador - Espaçador	Ø14x9 Foro 8,5mm	C14L9F8,5T	1
24	Distanziale - Spacer - Entretoise - Distanzstueck Distanciador - Espaçador	Ø18x20 Foro 8,5mm	C18L20F8,5T	4
25	Funghetto - Support hooks Befestigungspilz - Crochets support Gancho de soporte - Gancho de Suporte	-	Z125X-2	1
26	Piastrina - Little Plate Petite Plaque - Plaettchen Plaqueta - Plaquetas	-	GN1008V	1
27	Cavalotto - Retaining clamp Patte de fixation - Abrazadera Halteklammern - Abraçadeira de fixação	-	GNB1919V	1
28	Protezione Adesiva - Adhesive Protection Protection Adhesive - Schutzkleber Protección Adhesiva - Proteção Adesiva	-	Z2388	1
29	Tappo - Cap - Fiche - Stecker Enchufe - Capa	-	13COP	8
30	Tappo - Cap - Fiche - Stecker Enchufe - Capa	-	10COP	2
31	Protezione Adesiva - Adhesive Protection - Protection Adhesive Schutzkleber - Protección Adhesiva - Proteção Adesiva	35mmX3mmX150mm	MOUSSE 02	1
32	Componenti Originali - Original Parts Parties Originales - Original Bauteile Componentes Originales - Componentes Originais	-	-	-
33	Particolari Inclusi nel 02RKIT Components Included In The 02RKIT Pièces Incluses Dans 02RKIT Die Einzelnen Teile Sind Bei 02RKIT Despieces Incluidos 02RKIT Componentes incluidos na 02RKIT	-	-	-

IT_Nel caso in cui sulle viti originali sia presente del frenafilletti, ripristinarlo durante il montaggio dell'accessorio.

EN_If there is threadlocker on the original screws, use threadlocker when mounting the accessory.

DE_Falls sich auf den Originalschrauben Schraubensicherungsklebstoff befand, sollte dieser auch bei der Montage des Zubehörs wieder aufgetragen werden

FR_Si du frein filet est présent sur les vis d'origine, l'appliquer également lors du montage de l'accessoire

ES_En caso de que el fijador de roscas se encuentre presente en los tornillos originales, colocarlo nuevamente en el montaje del accesorio

PT_Se houver trava rosca nos parafusos originais, inserir novamente durante a montagem do acessório

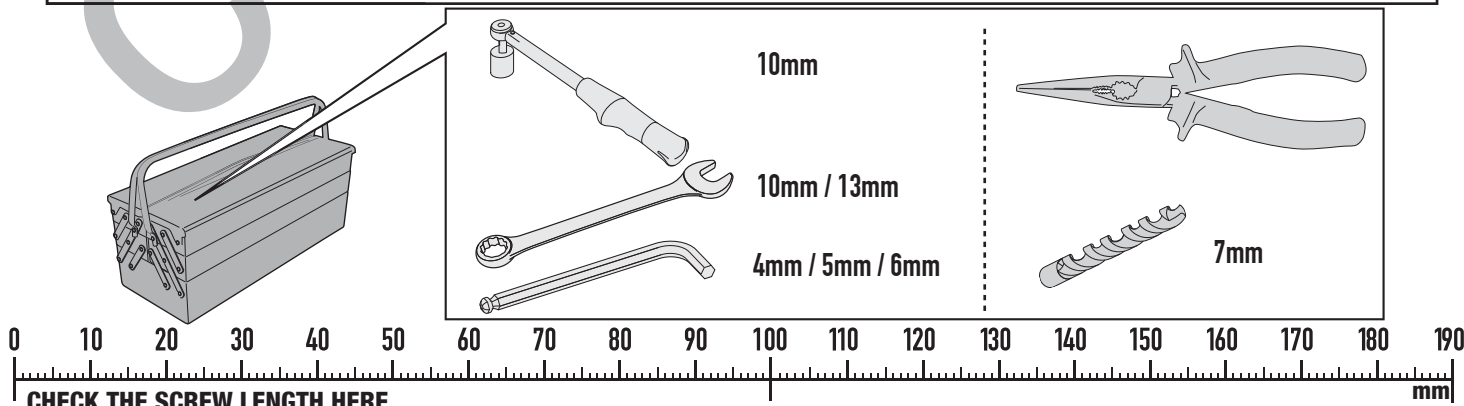

CHECK THE SCREW LENGTH HERE

ISTRUZIONI DI MONTAGGIO - MOUNTING INSTRUCTIONS
INSTRUCTIONS DE MONTAGE - BAUANLEITUNG
INSTRUCCIONES DE MONTAJE - INSTRUÇÕES DE MONTAGEM

GIVI

PLOS1178CAM

PORTAVALIGIE LATERALE SPECIFICO - SPECIFIC TUBULAR SIDE-CASE HOLDER - PORTE-VALISES LATÉRAUX SPÉCIFIQUE
 SPEZIFISCHES STAHLROHR-SEITENTRAEGER - PORTA MALETAS LATERALES ESPECÍFICO - SUPORTE DE MALAS ESPECÍFICO

HONDA CRF1100L AFRICA TWIN (2020/2024)/

HONDA CRF1100L AFRICA TWIN ADVENTURE SPORTS (2020/2024)

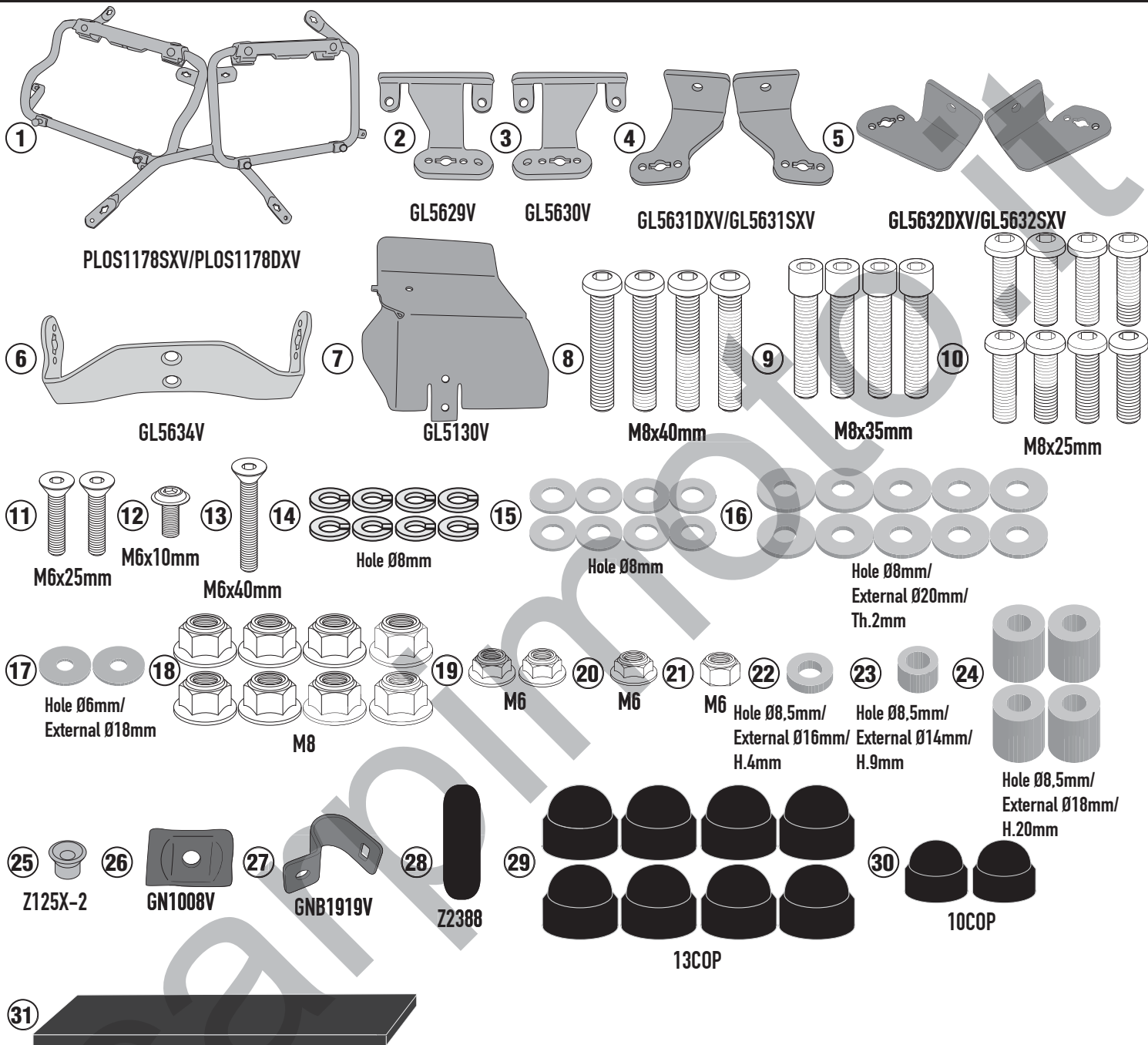

PLOS1178CAM

PORTAVALIGIE LATERALE SPECIFICO - SPECIFIC TUBULAR SIDE-CASE HOLDER - PORTE-VALISES LATÉRAUX SPÉCIFIQUE
SPEZIFISCHES STAHLROHR-SEITENTRAEGER - PORTA MALETAS LATERALES ESPECÍFICO - SUPORTE DE MALAS ESPECÍFICO

HONDA CRF1100L AFRICA TWIN (2020/2024)/

HONDA CRF1100L AFRICA TWIN ADVENTURE SPORTS (2020/2024)

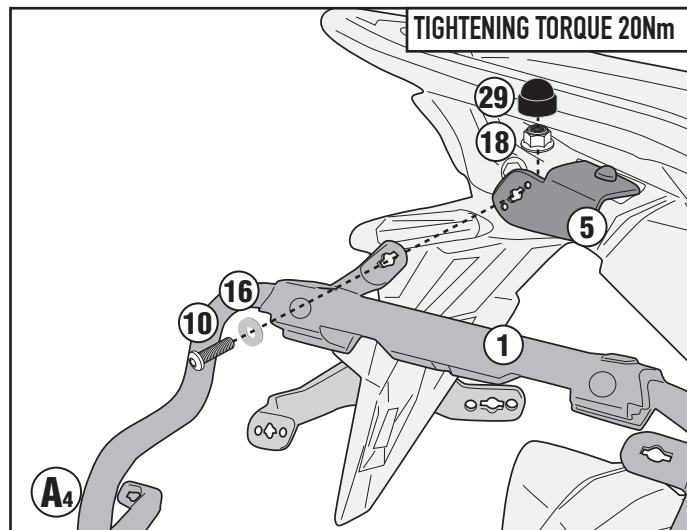
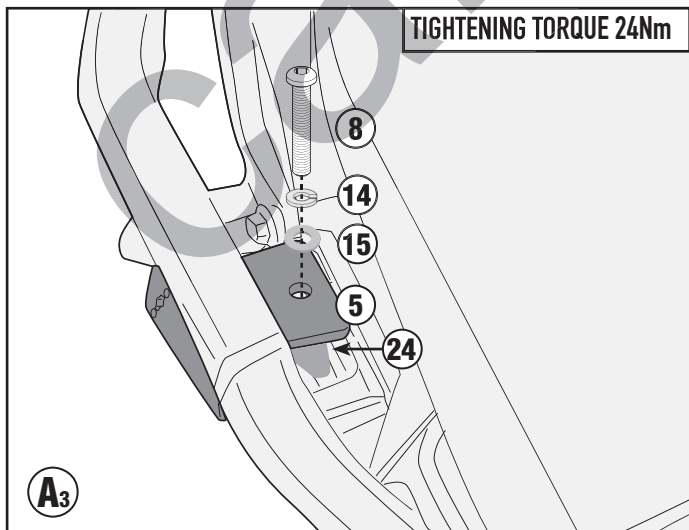
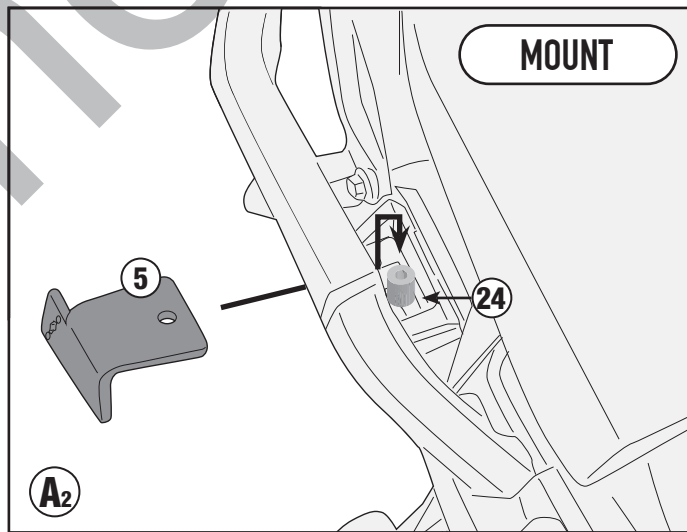
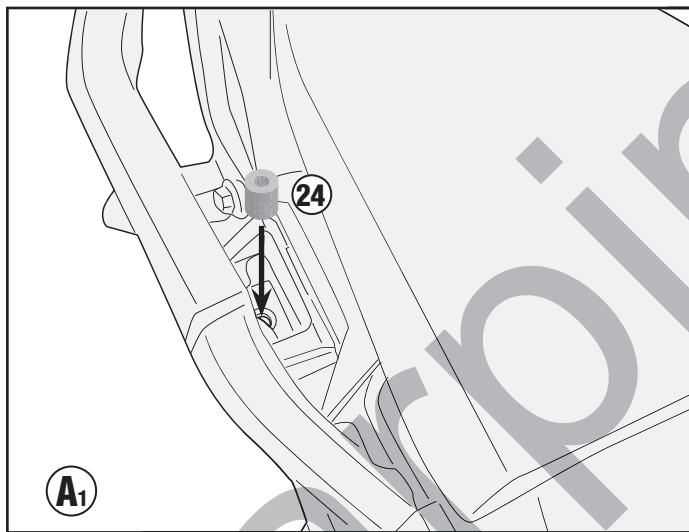
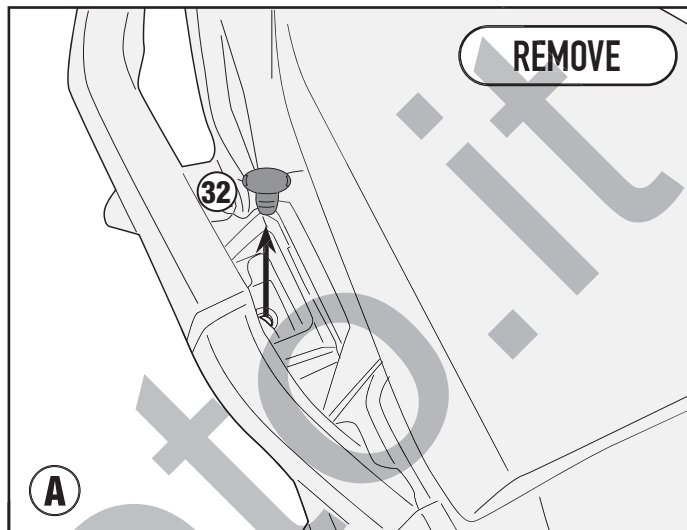
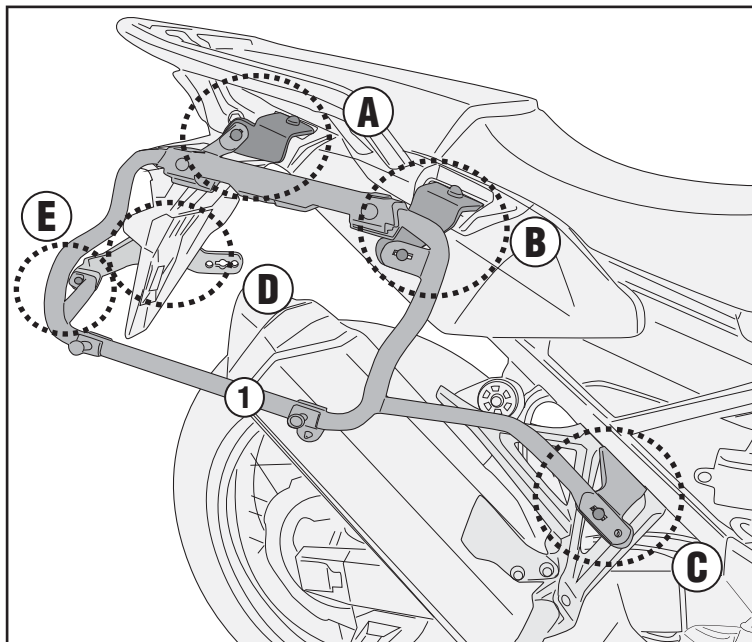

PLOS1178CAM

PORTAVALIGIE LATERALE SPECIFICO - SPECIFIC TUBULAR SIDE-CASE HOLDER - PORTE-VALISES LATÉRAUX SPÉCIFIQUE
SPEZIFISCHES STAHLROHR-SEITENTRAEGER - PORTA MALETAS LATERALES ESPECÍFICO - SUPORTE DE MALAS ESPECÍFICO

HONDA CRF1100L AFRICA TWIN (2020/2024)/

HONDA CRF1100L AFRICA TWIN ADVENTURE SPORTS (2020/2024)

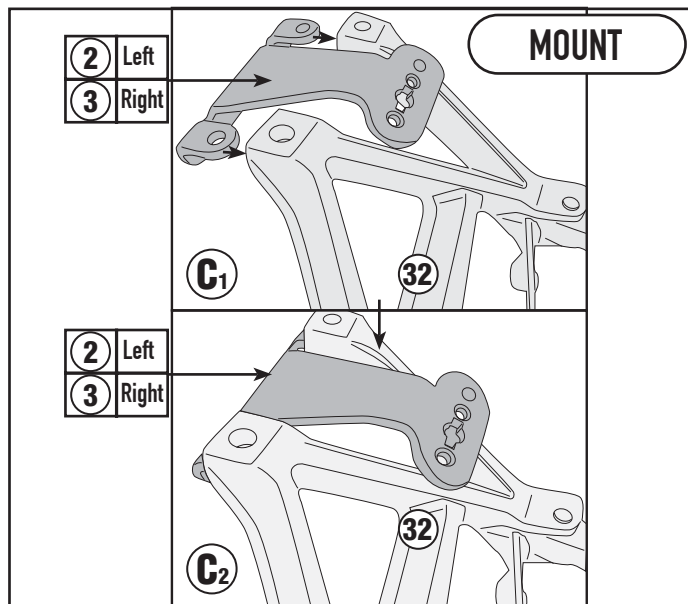
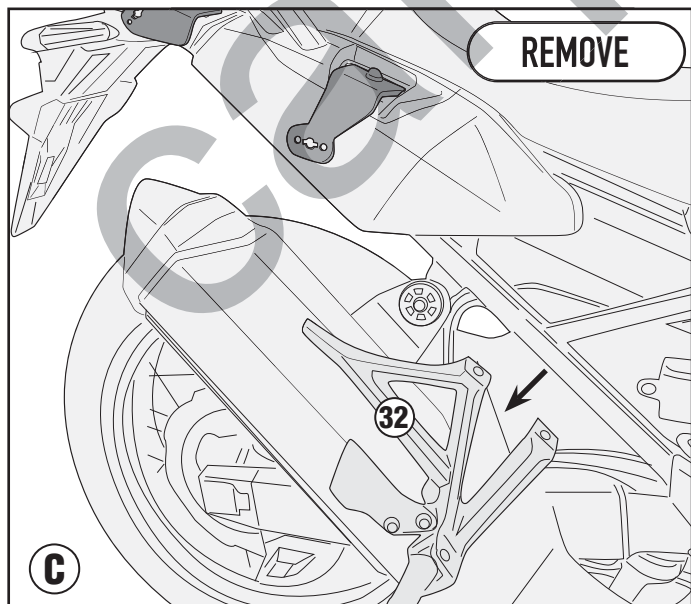
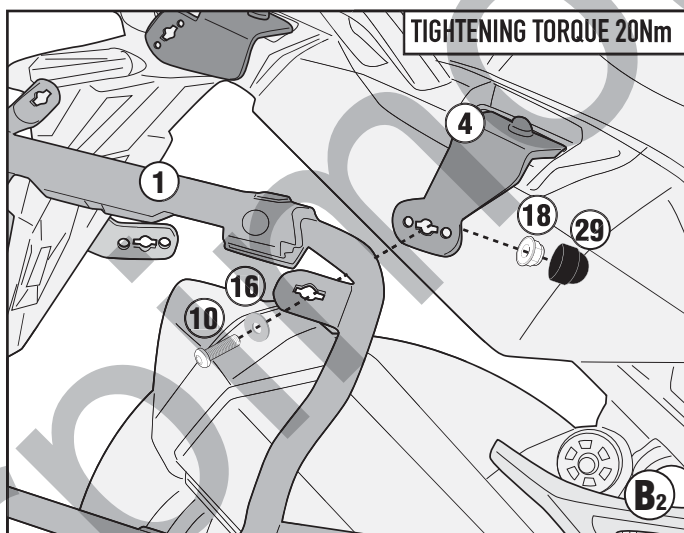
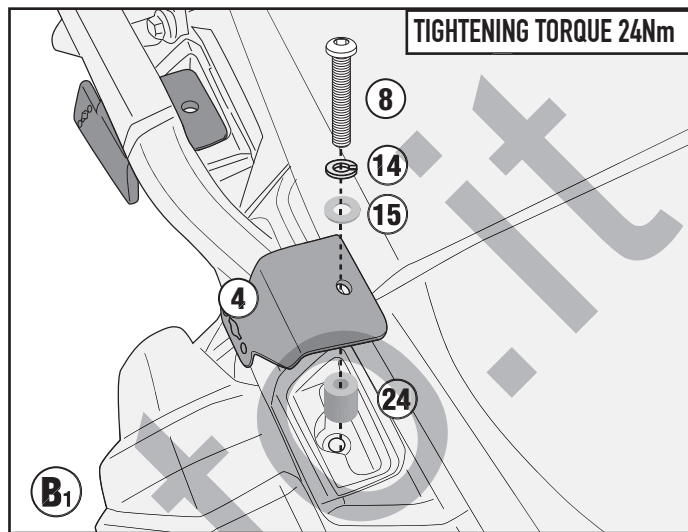
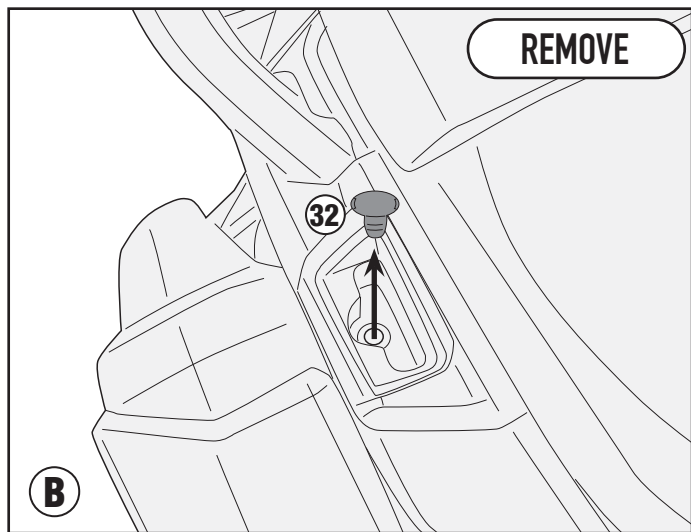

ISTRUZIONI DI MONTAGGIO - MOUNTING INSTRUCTIONS
INSTRUCTIONS DE MONTAGE - BAUANLEITUNG
INSTRUCCIONES DE MONTAJE - INSTRUÇÕES DE MONTAGEM

PLOS1178CAM

PORTAVALIGIE LATERALE SPECIFICO - SPECIFIC TUBULAR SIDE-CASE HOLDER - PORTE-VALISES LATÉRAUX SPÉCIFIQUE
SPEZIFISCHES STAHLROHR-SEITENTRAEGER - PORTA MALETAS LATERALES ESPECÍFICO - SUPORTE DE MALAS ESPECÍFICO

HONDA CRF1100L AFRICA TWIN (2020/2024)/

HONDA CRF1100L AFRICA TWIN ADVENTURE SPORTS (2020/2024)

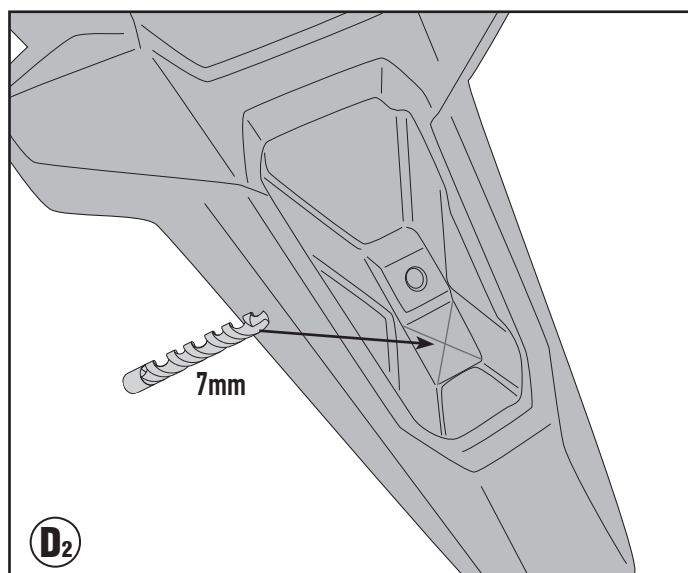
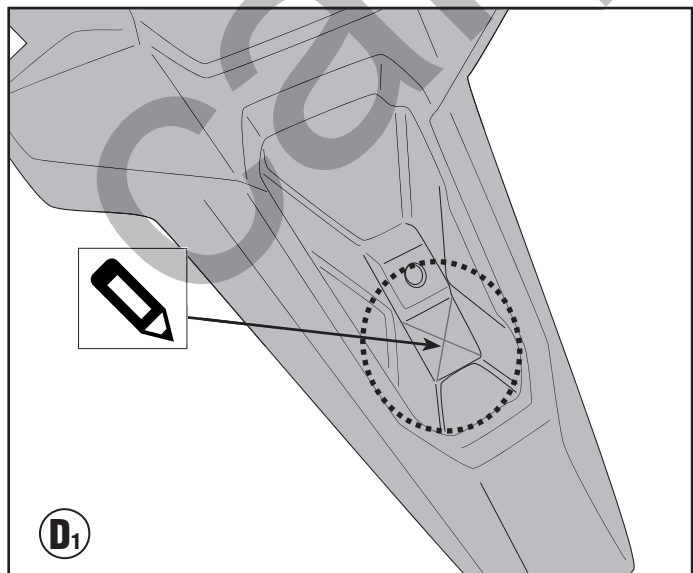
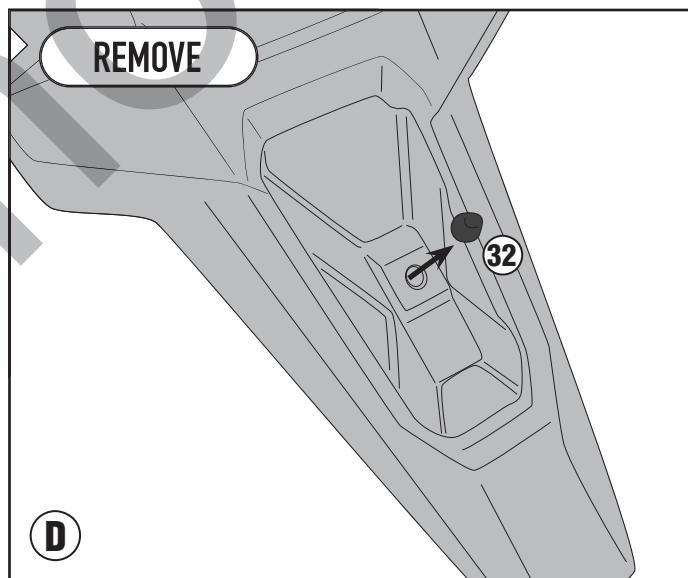
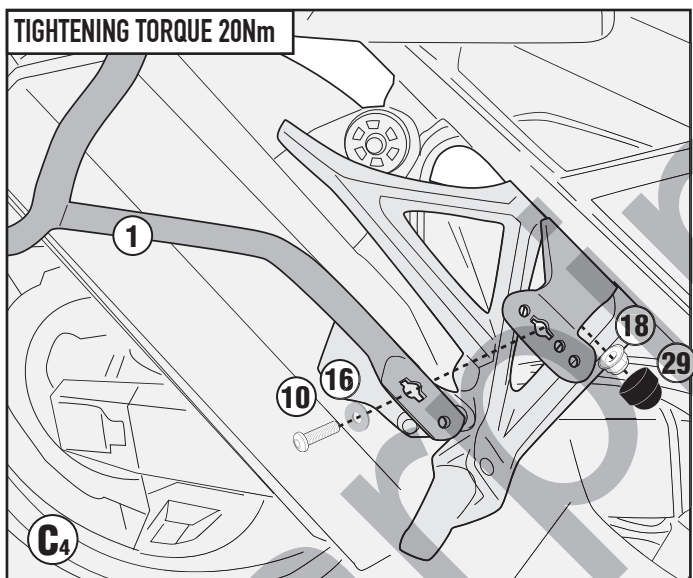
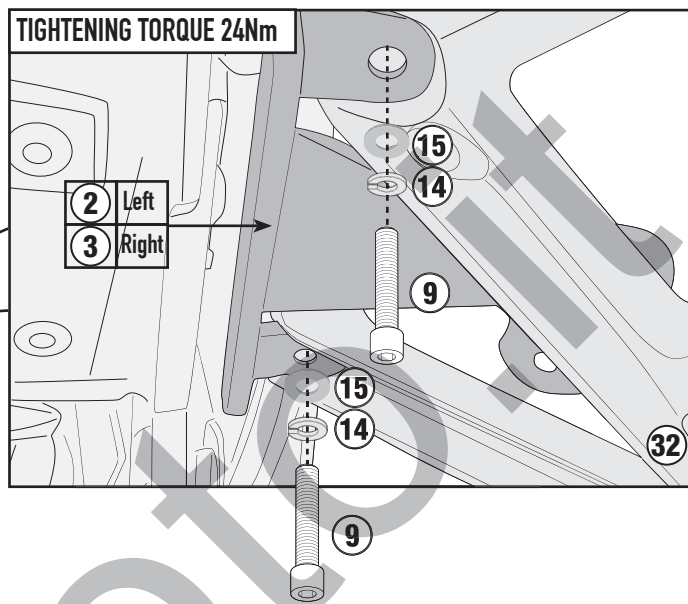
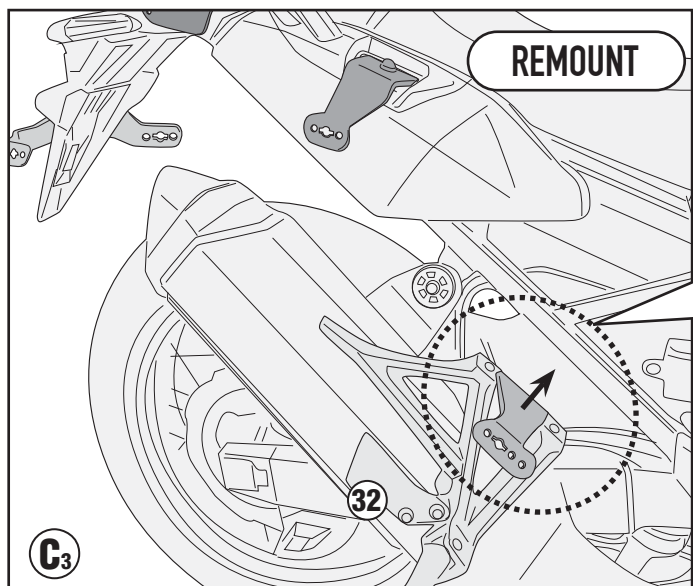

PLOS1178CAM

PORTAVALIGIE LATERALE SPECIFICO - SPECIFIC TUBULAR SIDE-CASE HOLDER - PORTE-VALISES LATÉRAUX SPÉCIFIQUE
SPEZIFISCHES STAHLROHR-SEITENTRAEGER - PORTA MALETAS LATERALES ESPECÍFICO - SUPORTE DE MALAS ESPECÍFICO

HONDA CRF1100L AFRICA TWIN (2020/2024)/

HONDA CRF1100L AFRICA TWIN ADVENTURE SPORTS (2020/2024)

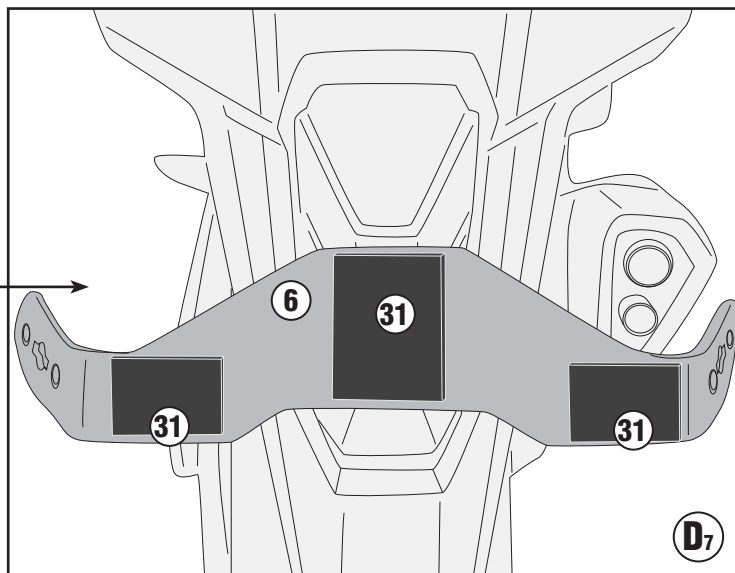
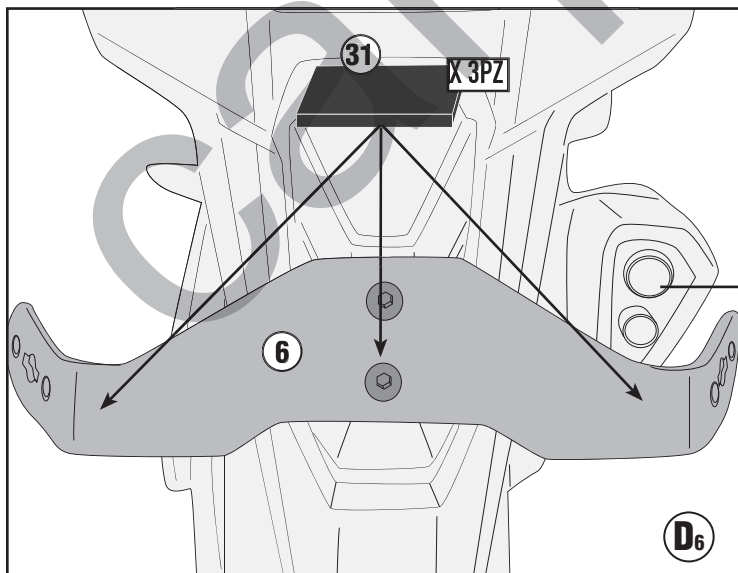
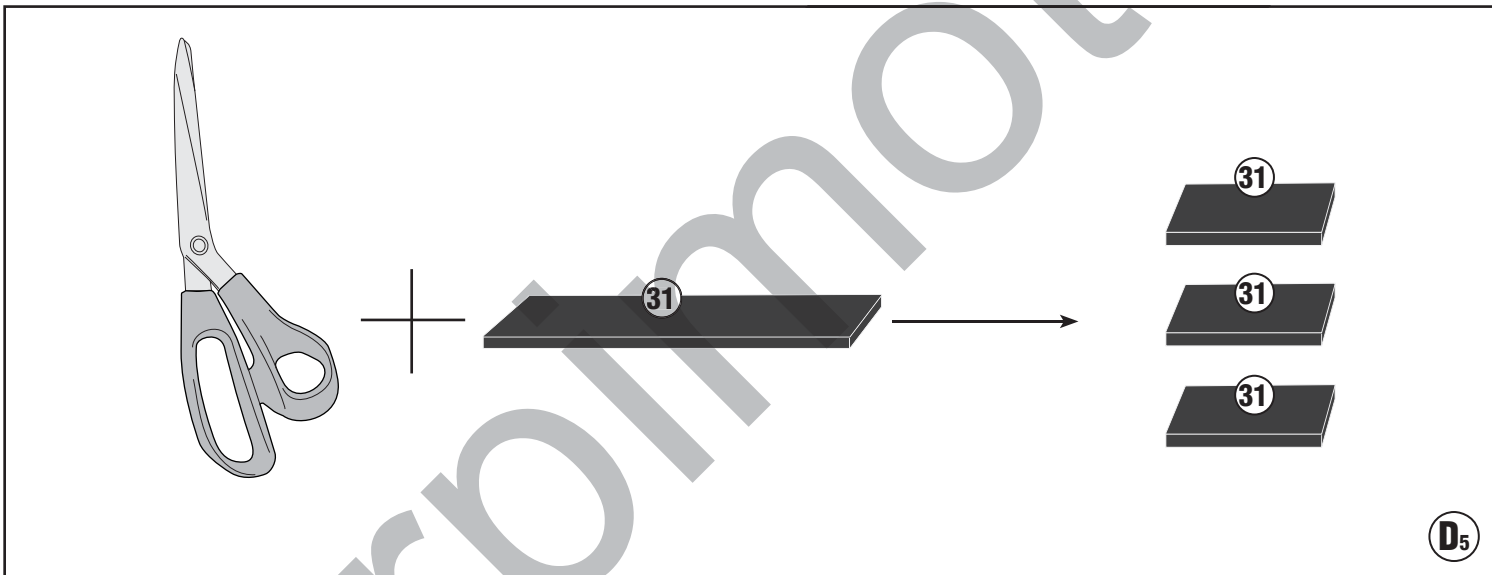
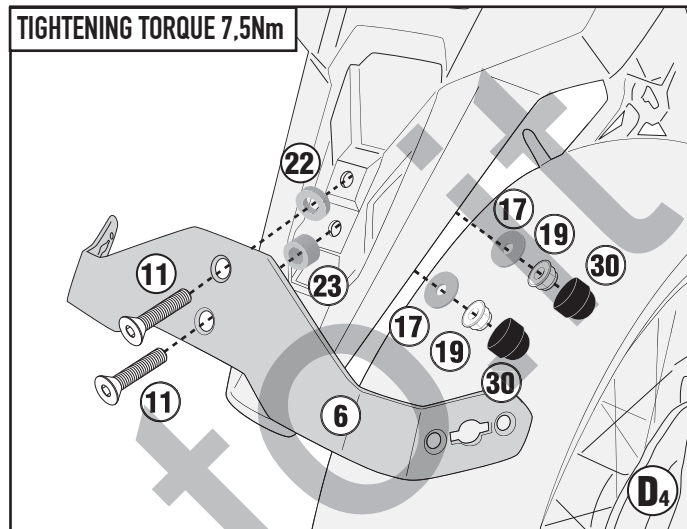
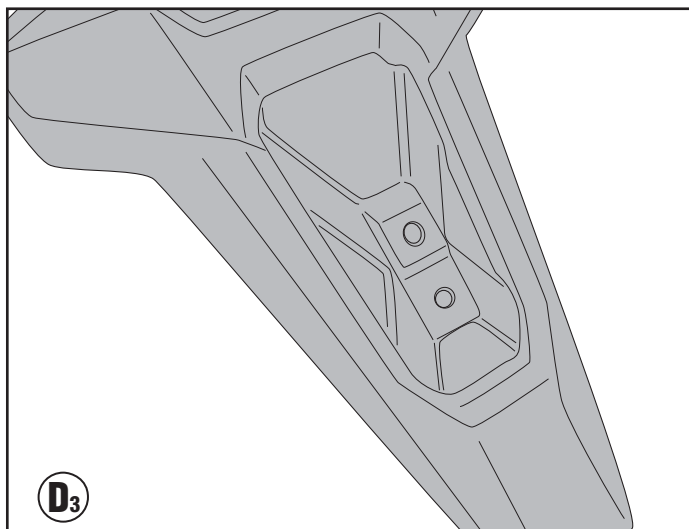

PLOS1178CAM

PORTAVALIGIE LATERALE SPECIFICO - SPECIFIC TUBULAR SIDE-CASE HOLDER - PORTE-VALISES LATÉRAUX SPÉCIFIQUE
SPEZIFISCHES STAHLROHR-SEITENTRAEGER - PORTA MALETAS LATERALES ESPECÍFICO - SUPORTE DE MALAS ESPECÍFICO

HONDA CRF1100L AFRICA TWIN (2020/2024)/

HONDA CRF1100L AFRICA TWIN ADVENTURE SPORTS (2020/2024)

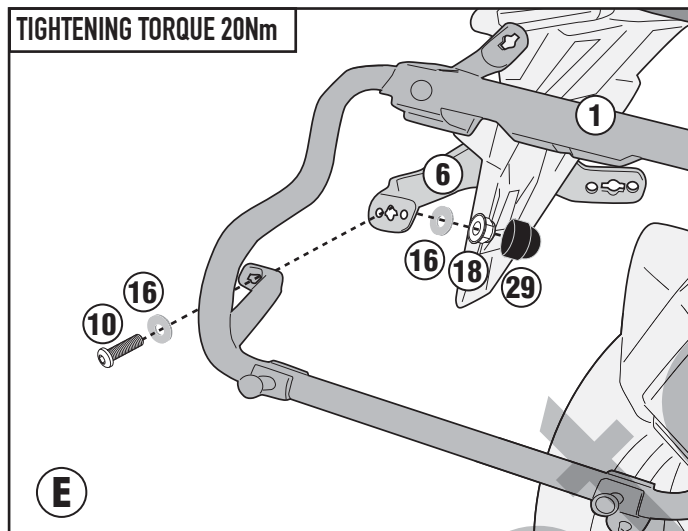

RIGHT SIDE

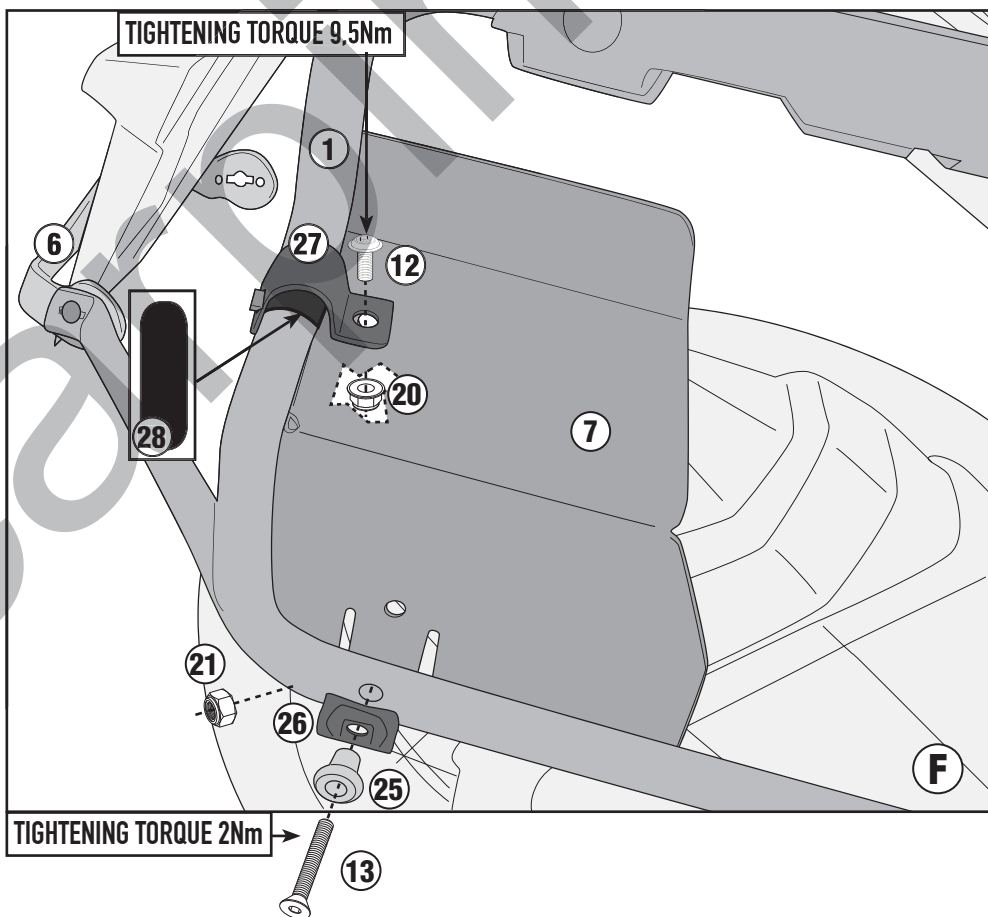

PLOS1178CAM

PORTAVALIGIE LATERALE SPECIFICO - SPECIFIC TUBULAR SIDE-CASE HOLDER - PORTE-VALISES LATÉRAUX SPÉCIFIQUE
SPEZIFISCHES STAHLROHR-SEITENTRAEGER - PORTA MALETAS LATERALES ESPECÍFICO - SUPORTE DE MALAS ESPECÍFICO

HONDA CRF1100L AFRICA TWIN (2020/2024)/

HONDA CRF1100L AFRICA TWIN ADVENTURE SPORTS (2020/2024)

- TRASFORMAZIONE IN PORTAVALIGIE LATERALI RAPID FITTING, AGGIUNGENDO IL KIT 02RKIT (DA ACQUISTARE SEPARATAMENTE)
- TRANSFORMATION INTO A RAPID FITTING SIDE-CASE HOLDER, BY ADDING THE 02RKIT KIT (TO BE PURCHASED SEPARATELY)
- VERARBEITUNG ZU EINEM SCHNELL MONTIERBAREN SEITENTRÄGER UNTER HINZUFÜGUNG DES 02RKIT-KITS (SEPARAT ZU ERWERBEN)
- TRANSFORMABLE EN KIT DE FIXATION LATÉRAL RAPIDE, EN AJOUTANT LE KIT 02RKIT (À ACHETER SÉPARÉMENT)
- SE TRANSFORMA EN UN PORTAMALETAS LATERAL DE AJUSTE RÁPIDO, AÑADIENDO EL KIT 02RKIT (SE COMPRA POR SEPARADO)
- CONVERTE EM UM RACK DE PAINEL LATERAL DE ENCAIXE RÁPIDO, ADICIONANDO O KIT 02RKIT (ADQUIRIDO SEPARADAMENTE)

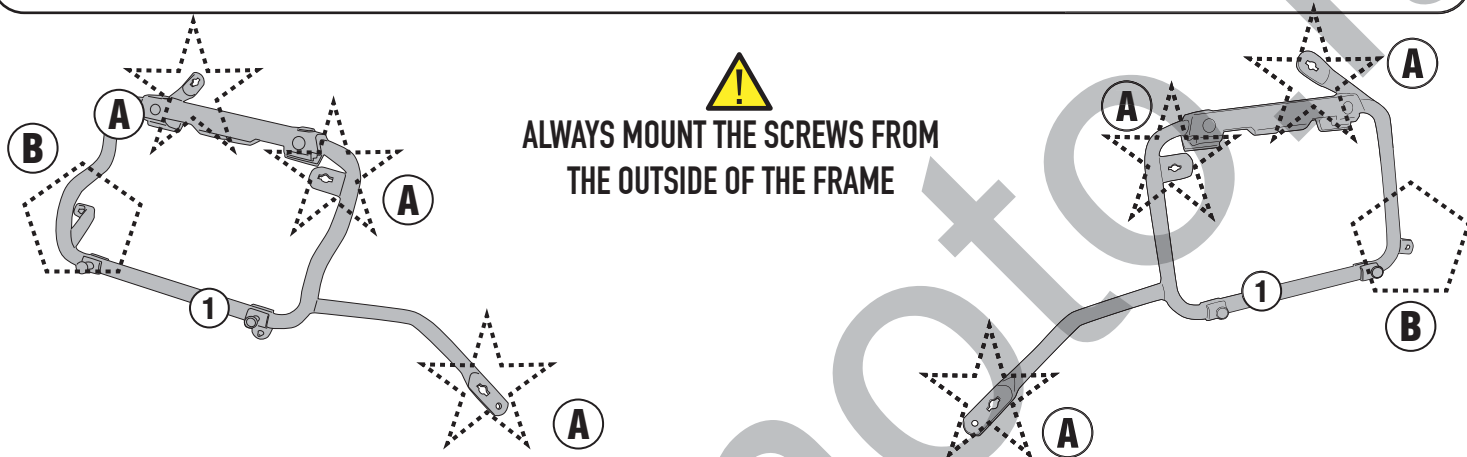

★ TYPE A

(See the figure above for the correct type)

CORRECT SIDE

INSERT
ATTENTION TO THE
CORRECT ASSEMBLY

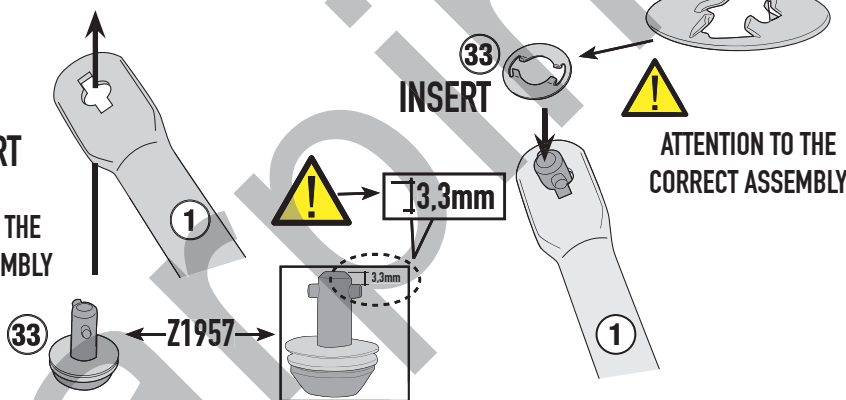

☆ TYPE B

(See the figure above for the correct type)

CORRECT SIDE

INSERT
ATTENTION TO THE
CORRECT ASSEMBLY

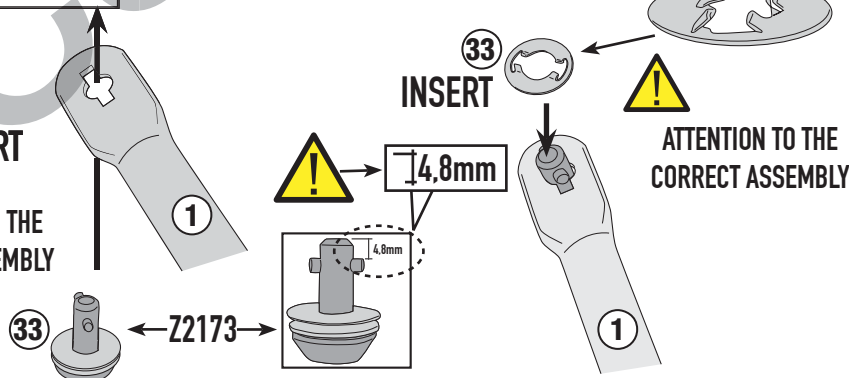

PLOS1178CAM

PORTAVALIGIE LATERALE SPECIFICO - SPECIFIC TUBULAR SIDE-CASE HOLDER - PORTE-VALISES LATÉRAUX SPÉCIFIQUE
 SPEZIFISCHES STAHLROHR-SEITENTRAEGER - PORTA MALETAS LATERALES ESPECÍFICO - SUPORTE DE MALAS ESPECÍFICO

HONDA CRF1100L AFRICA TWIN (2020/2024)/

HONDA CRF1100L AFRICA TWIN ADVENTURE SPORTS (2020/2024)

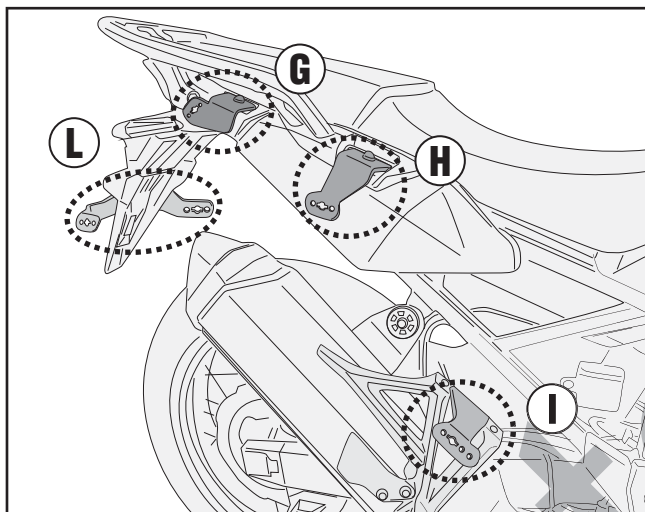

MOUNT IN THE REAR SIDE

TIGHTENING TORQUE 2Nm

ATTENTION TO THE CORRECT ASSEMBLY

LATO SVASATO FLARING SIDE

REAR SIDE LATO PIATTO FLAT SIDE

33 (M4 X 12 TSPX)

33 (M4 X 12 TSPX)

5

G

MOUNT IN THE REAR SIDE

TIGHTENING TORQUE 2Nm

ATTENTION TO THE CORRECT ASSEMBLY

LATO SVASATO FLARING SIDE

REAR SIDE LATO PIATTO FLAT SIDE

33 (M4 X 12 TSPX)

33 (M4 X 12 TSPX)

4

H

MOUNT IN THE REAR SIDE

TIGHTENING TORQUE 2Nm

ATTENTION TO THE CORRECT ASSEMBLY

LATO SVASATO FLARING SIDE

REAR SIDE LATO PIATTO FLAT SIDE

33 (M4 X 12 TSPX)

33 (M4 X 12 TSPX)

2 Left

3 Right

2 Left

3 Right

I

PLOS1178CAM

PORTAVALIGIE LATERALE SPECIFICO - SPECIFIC TUBULAR SIDE-CASE HOLDER - PORTE-VALISES LATÉRAUX SPÉCIFIQUE
SPEZIFISCHES STAHLROHR-SEITENTRAEGER - PORTA MALETAS LATERALES ESPECÍFICO - SUPORTE DE MALAS ESPECÍFICO

HONDA CRF1100L AFRICA TWIN (2020/2024)/

HONDA CRF1100L AFRICA TWIN ADVENTURE SPORTS (2020/2024)

TIGHTENING TORQUE 2Nm

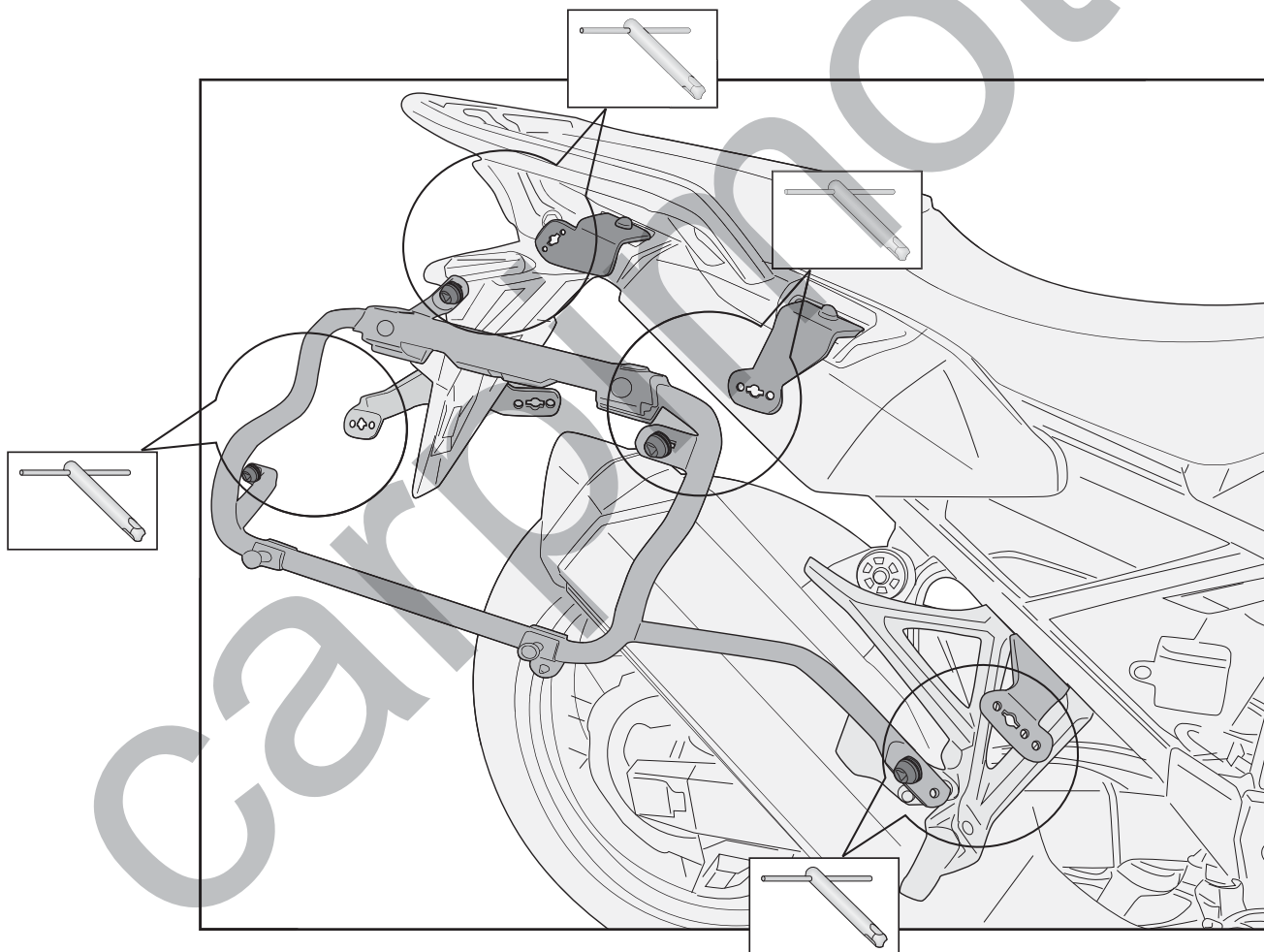
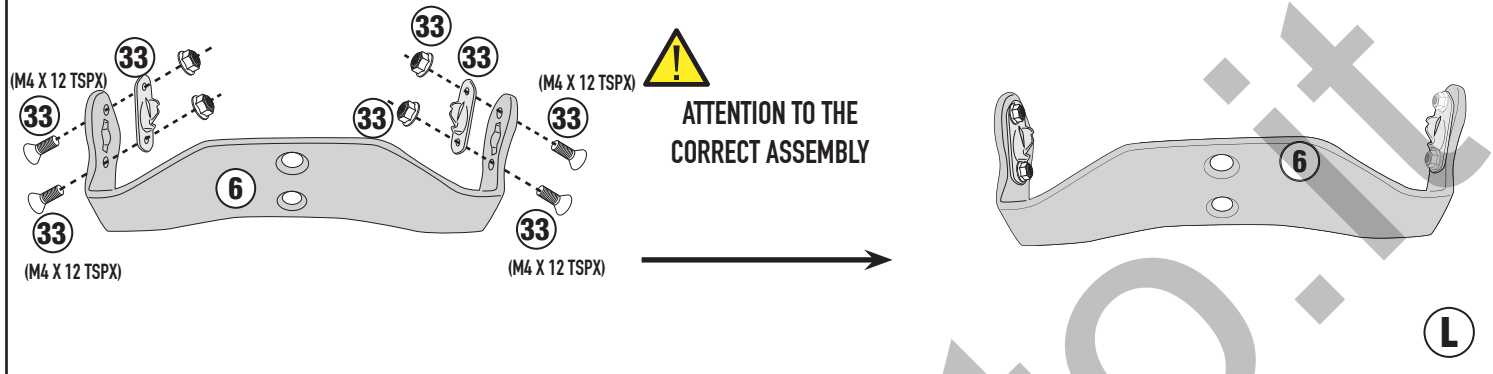

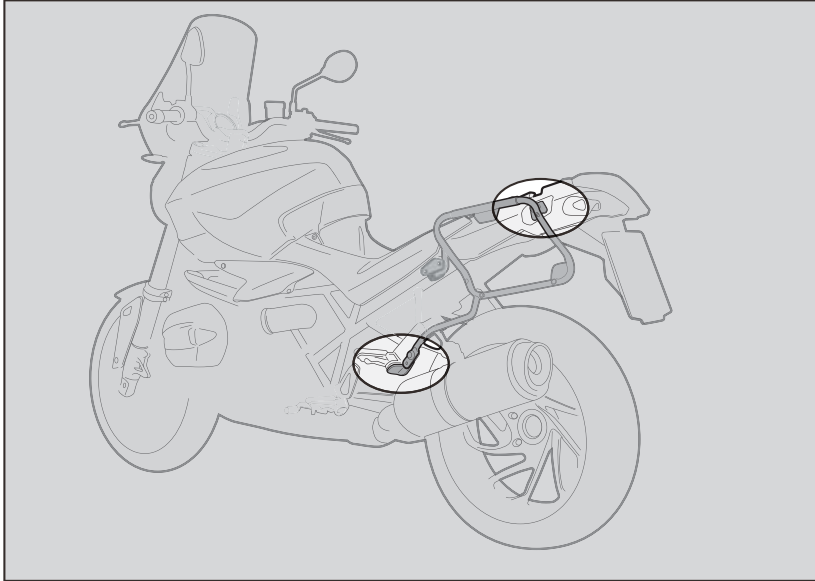

1. INSERIRE L'ATTREZZO NELLA TESTA DELLA VITE SPECIALE;
2. RUOTARE DI 1/4 DI GIRO IN SENSO ORARIO FINO A CHE LA ROTAZIONE NON TERMINA E SI AVVERTE LO SCATTO;
3. PER SMONTARE PROCEDERE IN SENSO INVERSO.

1. INSERT THE SPECIAL KEY INTO THE HEAD OF THE SCREW;
2. TURN THE KEY ¼ TURN CLOCKWISE UNTIL ROTATION STOPS AND THE SIDE CASE HOLDER IS FASTENED SECURELY TO THE FITMENT POINT;
3. IN ORDER TO DISASSEMBLE THE BRACKETRY PERFORM THE OPERATION IN REVERSE.

1. INSERER LA CLE SPECIALE DANS LA TÊTE DE LA VIS;
2. VISSER D'1/4 DE TOUR DANS LE SENS HORAIRE JUSQU'AU BLOCAGE DE LA VIS POUR MONTER EN TOUTE SECURITE LE SUPPORT A SON POINT DE FIXATION;
3. POUR LE DEMONTAGE, PROCEDER EN SENSE INVERSE.

1. STECKEN SIE DAS WERKZEUG IN DEN KOPF DER SPEZIFISCHEN SCHRAUBE;
2. DREHEN SIE DIE SCHRAUBE 1 / 4 UMDREHUNG IM UHRZEIGERSINN BIS SIE BEMERKEN, DASS DIE SCHRAUBE IM BEFESTIGUNGSPUNKT EINGEKLEMMT IST;
3. FÜR DIE DEMONTAGE FOLGEN SIE DEN HINWEISE UMGEKEHRT.

1. INSERTAR LA LLAVE ESPECIAL EN LA CABEZA DEL TORNILLO
2. DAR ¼ DE VUELTA EN EL SENTIDO HORARIO HASTA QUE LLEGUE AL TOPE Y SE VEA EL TORNILLO;
3. PARA DESMONTARLO PROCEDER EN LA DIRECCIÓN CONTRARIA;

MONTAGGIO - ASSEMBLY - MONTAGE - MONTAGE - MONTAJE

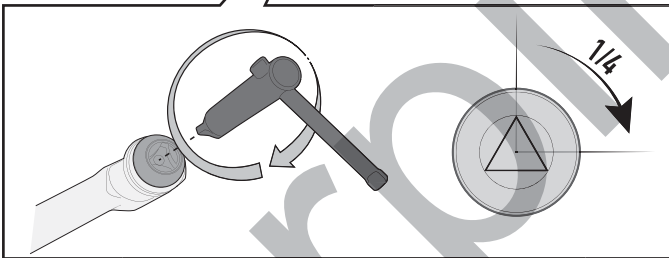
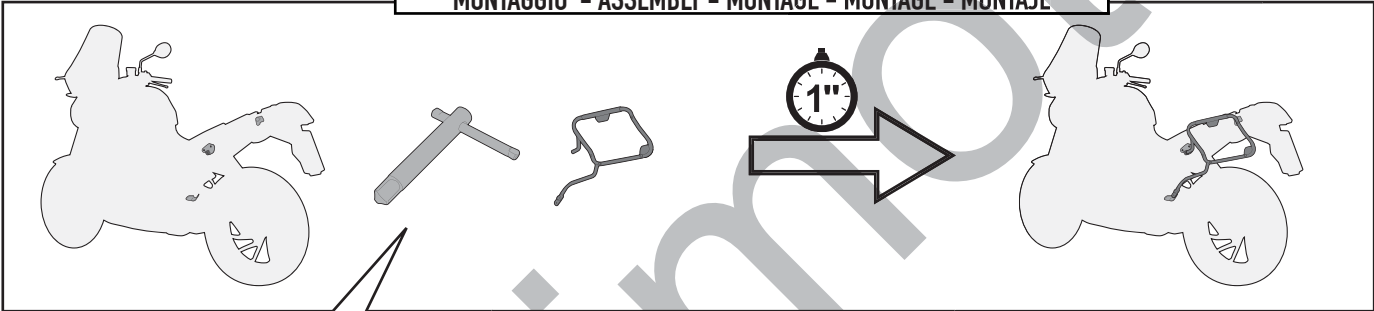

SMONTAGGIO - DISASSEMBLY - DÉMONTAGE - DEMONTAGE - DESMONTAJE

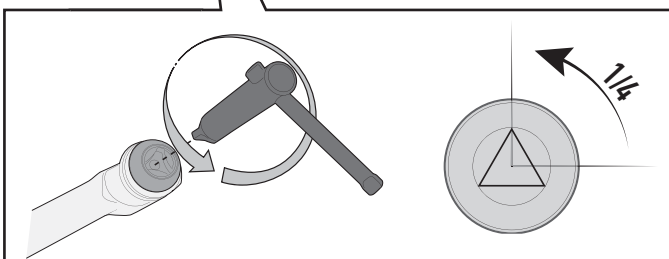
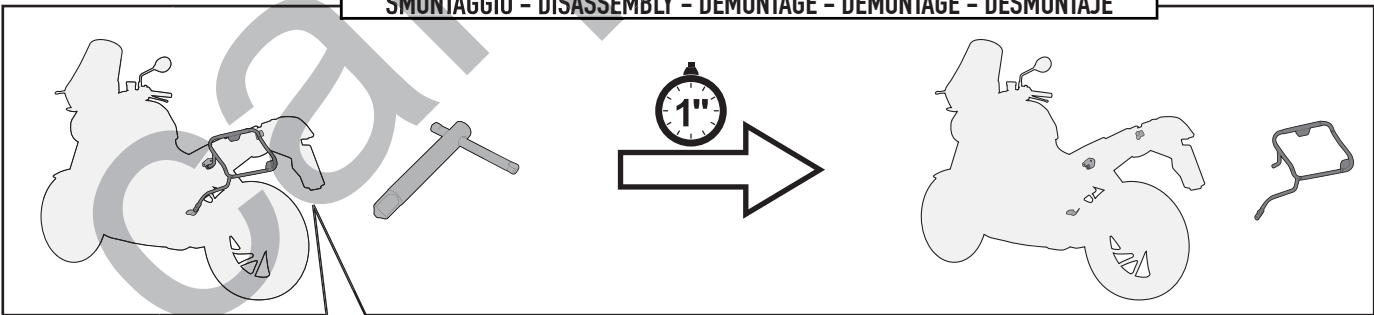

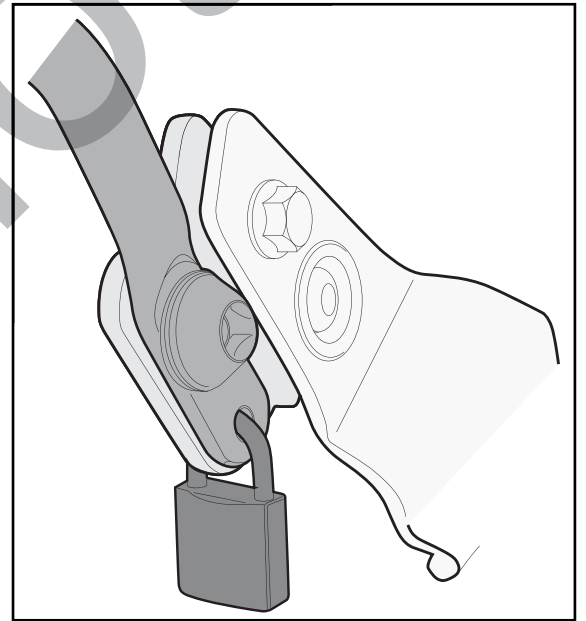
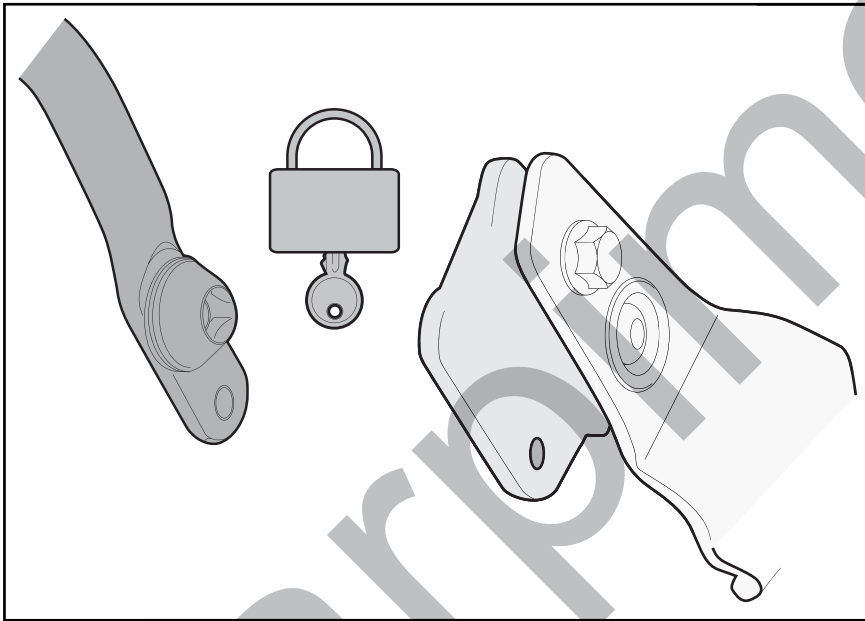
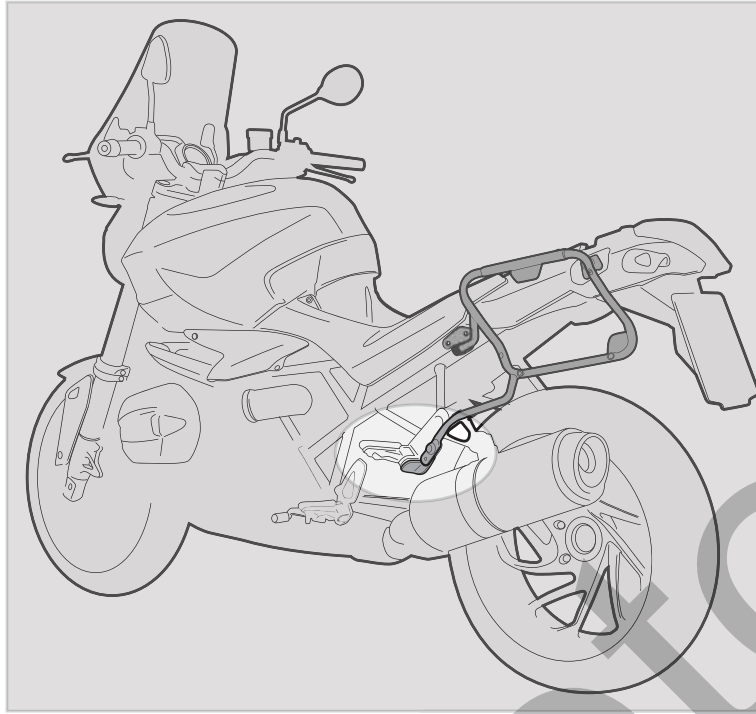

FORO DI SICUREZZA

FORO PREDISPOSTO AD ASSICURARE IL PORTAVALIGE LATERALE ALLA MOTO (CON UN LUCCHETTO PER ESEMPIO, NON INCLUSO).

SECURITY HOLE

HOLE PLACEMENT IN ORDER TO INCREASE SECURITY OF THE TUBULAR SIDE-CASE HOLDER TO THE MOTORCYCLE (WITH A LOCK, FOR EXAMPLE, NOT INCLUDED).

TROU DE SECURITE

TROU PREDISPOSE POUR ASSURER LE PORTE-VALISE LATERAL A LA MOTO (AVEC UN CADENAS PAR EXEMPLE, NON INCLUS).

SICHERHEITSLÖCH

VORGESEHENES LOCH UM DEN SEITENKOFFER TRÄGER AN DEM FAHRZEUG ZU SICHERN (Z. B. MIT EINEM VORHÄNGESCHLOSS, NICHT ENTHALTEN).

ORIFICIO DE SEGURIDAD

ESTE ORIFICIO ESTA CREADO PARA ASEGURAR EL PORTAEQUIPAJES LATERAL A LA MOTO (POR EJEMPLO CON UN CANDADO, QUE NO ESTÁ INCLUIDO).